



TELEDYNE
JUDSON TECHNOLOGIES
A Teledyne Technologies Company

Photovoltaic Mercury Cadmium Telluride Detectors

Teledyne Judson Technologies LLC

221 Commerce Drive
Montgomeryville, PA 18936 USA

Tel: 215-368-6900

Fax: 215-362-6107

Visit us on the web.

www.teledynejudson.com

General

J19 series detectors are high-quality HgCdTe (MCT) photodiodes for use in the 500nm to 5.5 μm spectral range. The equivalent circuit is a photon-generated current source I_{ph} with parallel capacitance C_D , shunt resistance R_D , and series resistance R_S . (Figure 1)

Figure 1
Photodiode Equivalent Circuit

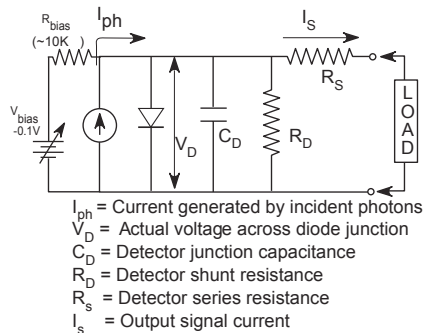

Temperature Effects

Cooling an MCT photodiode increases its shunt resistance which results in reduced noise and improved detectivity. Figures 2 and 3 show the relationship between detector temperature and detectivity (D^*) as a function of wavelength. The D^* plots in Figure 2 are for a detector with an active size of 1mm, 50% cutoff wavelength at 5 μm and operating from -20C to -90C. The detectors are mounted on thermoelectric coolers (TEC) where one-stage (TE1) is used for -20C operation and subsequent stages (TE2, TE3 and TE4) are used to achieve lower temperatures. Similarly, Figure 3 shows a series of plots for D^* vs. wavelength for a detector with an active size of 1mm, 50% cutoff wavelength at 2.8 μm and operating from room temperature (+22C) to -90C. The field of view (FOV) is 180 $^\circ$ except at -90C where the FOV is 60 $^\circ$.

Figure 2
 Typical D^* vs Wavelength for TE1-4, PV MCT, 5 μm cutoff, 1mm, 180 $^\circ$ FOV, 45 $^\circ$ FOV @ -90C

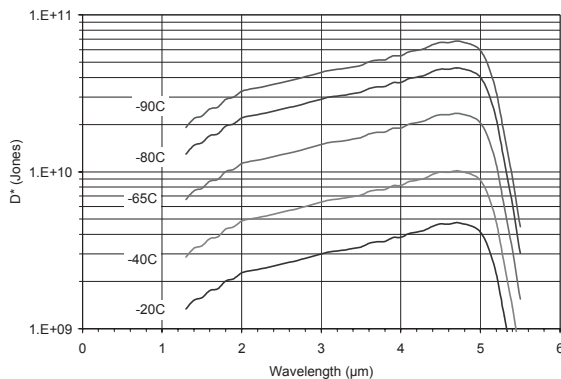
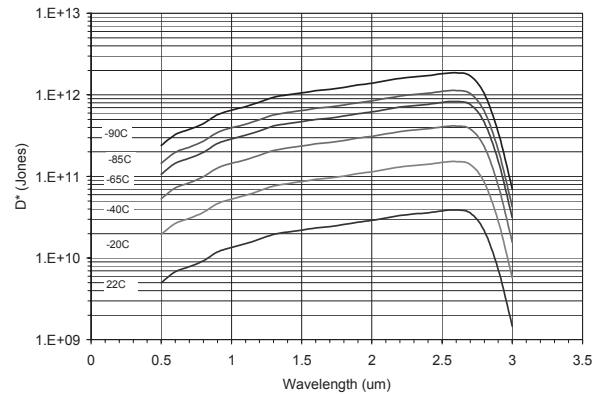

Figure 3
 Typical D^* vs Wavelength for room temperature and TE1-4, PV MCT, 2.8 μm cutoff, 1mm, 180 $^\circ$ FOV; 60 $^\circ$ FOV at -90C



Responsivity

Figures 4 and 5 show a typical spectral response for 1mm size, 5 μm and 2.8 μm cutoff, respectively. Please refer to Tables 1, 2 and 3 for further detector specifications for 2.8 μm , 5 μm and 5.5 μm wavelength cutoffs, respectively.

Figure 4
 Typical Spectral Response, PV MCT, 5 μm cutoff, 1mm, TE1-4, 180 $^\circ$ FOV

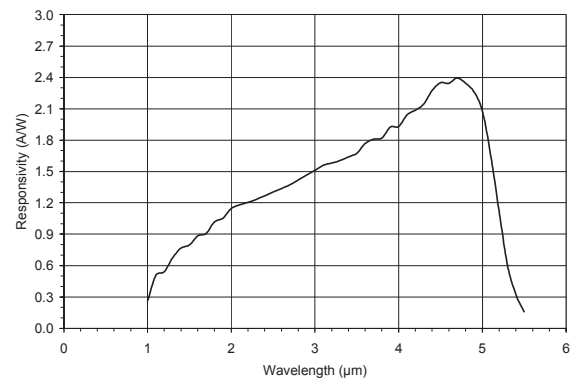
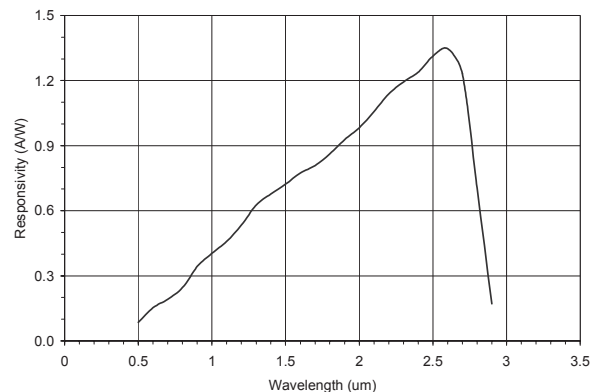

Figure 5
 Typical Spectral Response, PV MCT, 2.8 μm cutoff, 1mm, 180 $^\circ$ FOV



Thermoelectric Cooler Operation

Teledyne Judson offers a variety of convenient packages for room temperature and thermoelectrically (TE) cooled operation. Typical power requirements for the TE2, TE3 and TE4 coolers are shown in Figures 8, 9 and 10 on page 5. The built in thermistor can be used to monitor or control the temperature. Figure 6 shows typical thermistor resistance vs. temperature values. Sensitivity and cutoff wavelength are functions of temperature. Detector temperature should be optimized for a particular application.

Figure 6
 Typical Thermistor Curve

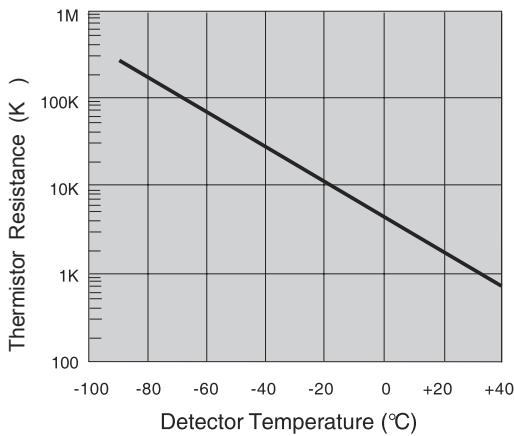

Operating Circuit

The recommended operating circuit for most applications is an operational amplifier in a negative-feedback transimpedance configuration (Figure 7) with up to 0.1V reverse bias put across the detector. This reverse bias will increase the effective shunt impedance of the detector but will also increase the detector 1/f noise.

Figure 7
 Typical Operating Circuit

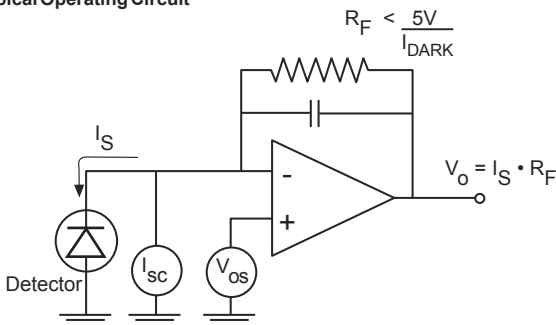

Advantages of Photovoltaic MCT

Unlike the MCT photoconductors commonly used in the 750nm to 5.5µm region, MCT photodiodes operate in the photovoltaic mode and can operate at zero bias. J19 detectors are a better choice for DC and low-frequency applications as they exhibit low 1/f noise characteristics as compared to PbS, PbSe and HgCdTe photoconductors.

J19 detectors also offer superior pulse response for applications in monitoring and detecting high-speed pulsed lasers. They do not require a chopper and exhibit better linearity than photoconductive detectors.

Accessories

A thermoelectrically cooled detector requires a heat sink to dissipate the heat generated by the cooler, an amplifier to amplify the detector signal to a usable level and a temperature controller to hold the detector at a constant temperature. Teledyne Judson TE cooler accessories are designed to provide solutions for our customers.

The CMAMP series is designed for customers that would like a fully integrated detector module. It includes heatsinking, detector signal amplification and temperature control. We also offer heat sink assemblies without preamps or temperature controllers. Please ask customer service for Product Bulletin PB4102 for more information.

Cooler / Preamplifier Recommendations

| Detector Shunt Impedance | Recommended Cooler Module | Part Number |
|--------------------------|---------------------------|-------------|
| < 400Ω | CMAMP-TO66-PA5 | 490130 |
| | CMAMP-3CN-PA5 | 490132 |
| 400Ω – 50KΩ | CMAMP-TO66-PA6 | 490146 |
| | CMAMP-3CN-PA6 | 490211 |
| > 25KΩ | CMAMP-TO66-PA7 | 490139 |
| | CMAMP-3CN-PA7 | 490141 |

CMAMP assembly includes heat sink, temperature controller and transimpedance amplifier for the J19TE packages.

NEW Table 1. 2.8µm Cutoff Room Temperature and Thermoelectrically Cooled PV MCT, One Through Four Stages (TE1-4)

| Detector Model Number | Detector Part Number | Active Size Diameter (mm) | Operating Temp. (°C) | 50% Cutoff Wavelength Typ (µm) | Peak Wavelength Typ (µm) | Peak Responsivity (A/W) Min | Shunt impedance (Ohm) | | Dark Current @ -0.1V (A) | | Peak D* (Jones) @ 1KHz | |
|-----------------------|----------------------|---------------------------|----------------------|--------------------------------|--------------------------|-----------------------------|-----------------------|---------|--------------------------|---------|------------------------|---------|
| | | | | | | | Min | Typ | Typ | Max | Min | Typ |
| J19:2.8-18C-R250U | 440045 | 0.25 | 22 | 2.8 | 2.6 | 1.3 | 7.5E+03 | 1.5E+04 | 2.0E-06 | 2.0E-05 | 2.0E+10 | 2.8E+10 |
| J19:2.8-18C-R01M | 440044 | 1.00 | 22 | 2.8 | 2.6 | 1.3 | 7.5E+02 | 1.5E+03 | 2.0E-05 | 2.0E-04 | 2.5E+10 | 3.5E+10 |
| J19TE1:2.8-66C-R250U | 440048 | 0.25 | -20 | 2.8 | 2.6 | 1.3 | 1.0E+05 | 2.0E+05 | 1.0E-07 | 1.0E-06 | 7.7E+10 | 1.1E+11 |
| J19TE1:2.8-66C-R01M | 440047 | 1.00 | -20 | 2.8 | 2.6 | 1.3 | 1.0E+04 | 2.0E+04 | 1.0E-06 | 1.0E-05 | 9.7E+10 | 1.4E+11 |
| J19TE2:2.8-66C-R250U | 440049 | 0.25 | -40 | 2.8 | 2.6 | 1.3 | 7.5E+05 | 1.5E+06 | 2.0E-08 | 2.0E-07 | 2.1E+11 | 2.9E+11 |
| J19TE2:2.8-66C-R01M | 440041 | 1.00 | -40 | 2.8 | 2.6 | 1.3 | 7.5E+04 | 1.5E+05 | 2.0E-07 | 2.0E-06 | 2.7E+11 | 3.7E+11 |
| J19TE3:2.8-66C-R250U | 440050 | 0.25 | -65 | 2.8 | 2.6 | 1.3 | 4.0E+06 | 8.0E+06 | 5.0E-09 | 5.0E-08 | 4.7E+11 | 5.9E+11 |
| J19TE3:2.8-66C-R01M | 440042 | 1.00 | -65 | 2.8 | 2.6 | 1.3 | 4.0E+05 | 8.0E+05 | 5.0E-08 | 5.0E-07 | 5.9E+11 | 7.4E+11 |
| J19TE4:2.8-3CN-R250U | 440051 | 0.25 | -85 | 2.8 | 2.6 | 1.3 | 1.6E+07 | 3.2E+07 | 3.0E-09 | 3.0E-08 | 7.2E+11 | 8.0E+11 |
| J19TE4:2.8-3CN-R01M | 440043 | 1.00 | -85 | 2.8 | 2.6 | 1.3 | 1.6E+06 | 3.2E+06 | 3.0E-08 | 3.0E-07 | 9.1E+11 | 1.0E+12 |
| J19TE4:2.8-3VN-R250U | TBA | 0.25 | -90 | 2.8 | 2.6 | 1.3 | 3.2E+07 | 6.4E+07 | 2.0E-09 | 2.0E-08 | 8.1E+11 | 8.6E+11 |
| J19TE4:2.8-3VN-R01M | TBA | 1.00 | -90 | 2.8 | 2.6 | 1.3 | 3.2E+06 | 6.4E+06 | 2.0E-08 | 2.0E-07 | 1.0E+12 | 1.1E+12 |

All specs are for detector operation at 0V bias and 180° FOV unless otherwise specified. Maximum reverse bias voltage for all detectors is 0.2V.

Table 2. 5.0µm Cutoff Thermoelectrically Cooled PV MCT, One Through Four Stages (TE1-4)

| Detector Model Number | Detector Part Number | Active Size Diameter (mm) | Operating Temp. (°C) | 50% Cutoff Wavelength Typ. (µm) | Peak Wavelength Typ. (µm) | Peak Responsivity (A/W) Min | Shunt impedance (Ohm) | | Dark Current (A) | | Peak D* (Jones) @ 10KHz | |
|-----------------------|----------------------|---------------------------|----------------------|---------------------------------|---------------------------|-----------------------------|-----------------------|---------|------------------|---------|-------------------------|---------|
| | | | | | | | Min | Typ | Typ | Max | Min | Typ |
| J19TE1:5-66C-R250U | 440052 | 0.25 | -20 | 5.0 | 4.5 | 1.5 | 2.0E+02 | 4.0E+02 | 5.0E-05 | 2.0E-04 | 4.0E+09 | 5.6E+09 |
| J19TE1:5-66C-R01M | 440038 | 1.00 | -20 | 5.0 | 4.5 | 1.0 | 2.0E+01 | 4.0E+01 | 5.0E-04 | 2.0E-03 | 3.4E+09 | 4.7E+09 |
| J19TE2:5-66C-R250U | 440016 | 0.25 | -40 | 5.0 | 4.5 | 1.7 | 5.0E+02 | 1.0E+03 | 2.0E-05 | 8.0E-05 | 7.4E+09 | 1.1E+10 |
| J19TE2:5-66C-R01M | 440017 | 1.00 | -40 | 5.0 | 4.5 | 1.3 | 5.0E+01 | 1.0E+02 | 2.0E-04 | 8.0E-04 | 7.2E+09 | 1.0E+10 |
| J19TE3:5-66C-R250U | 440008 | 0.25 | -65 | 5.0 | 4.5 | 1.9 | 1.6E+03 | 3.2E+03 | 6.0E-06 | 2.4E-05 | 1.6E+10 | 2.2E+10 |
| J19TE3:5-66C-R01M | 440010 | 1.00 | -65 | 5.0 | 4.5 | 1.6 | 1.6E+02 | 3.2E+02 | 6.0E-05 | 2.4E-04 | 1.7E+10 | 2.4E+10 |
| J19TE4:5-3CN-R250U | 440022 | 0.25 | -80 | 5.0 | 4.5 | 2.1 | 3.6E+03 | 7.2E+03 | 3.0E-06 | 1.2E-05 | 2.7E+10 | 3.8E+10 |
| J19TE4:5-3CN-R01M | 440023 | 1.00 | -80 | 5.0 | 4.5 | 2.0 | 3.6E+02 | 7.2E+02 | 3.0E-05 | 1.2E-04 | 3.3E+10 | 4.6E+10 |
| * J19TE4:5-3VN-R250U | 440053 | 0.25 | -90 | 5.0 | 4.5 | 2.2 | 6.0E+03 | 1.2E+04 | 2.0E-06 | 8.0E-06 | 3.8E+10 | 5.4E+10 |
| * J19TE4:5-3VN-R01M | 440037 | 1.00 | -90 | 5.0 | 4.5 | 2.2 | 6.0E+02 | 1.2E+03 | 2.0E-05 | 8.0E-05 | 4.8E+10 | 6.8E+10 |

All specs are for detector operation at 0V bias and 180° FOV unless otherwise specified. * 45° FOV. Maximum reverse bias voltage for all detectors is 0.5V. Higher responsivity may be achieved at reverse bias.

NEW Table 3. 5.5µm Cutoff Thermoelectrically Cooled PV MCT, One Through Four Stages (TE1-4)

| Detector Model Number | Detector Part Number | Active Size Diameter (mm) | Operating Temp. (°C) | 50% Cutoff Wavelength Typ. (µm) | Peak Wavelength Typ. (µm) | Peak Responsivity (A/W) Min | Shunt impedance (Ohm) | | Dark Current (A) | | Peak D* (Jones) @ 10KHz | |
|------------------------|----------------------|---------------------------|----------------------|---------------------------------|---------------------------|-----------------------------|-----------------------|---------|------------------|---------|-------------------------|---------|
| | | | | | | | Min | Typ | Typ | Max | Min | Typ |
| J19TE1:5.5-66C-R250U | 440054 | 0.25 | -20 | 5.5 | 5.0 | 1.7 | 1.0E+02 | 2.0E+02 | 1.0E-04 | 4.0E-04 | 3.2E+09 | 4.5E+09 |
| J19TE1:5.5-66C-R01M | 440055 | 1.00 | -20 | 5.5 | 5.0 | 1.2 | 1.0E+01 | 2.0E+01 | 1.0E-03 | 4.0E-03 | 2.8E+09 | 4.0E+09 |
| J19TE2:5.5-66C-R250U | 440018 | 0.25 | -40 | 5.5 | 5.0 | 1.9 | 2.5E+02 | 5.0E+02 | 4.0E-05 | 1.6E-04 | 5.9E+09 | 8.3E+09 |
| J19TE2:5.5-66C-R01M | 440019 | 1.00 | -40 | 5.5 | 5.0 | 1.5 | 2.5E+01 | 5.0E+01 | 4.0E-04 | 1.6E-03 | 5.9E+09 | 8.3E+09 |
| J19TE3:5.5-66C-R250U | 440020 | 0.25 | -65 | 5.5 | 5.0 | 2.1 | 8.0E+02 | 1.6E+03 | 1.2E-05 | 4.8E-05 | 1.2E+10 | 1.7E+10 |
| J19TE3:5.5-66C-R01M | 440021 | 1.00 | -65 | 5.5 | 5.0 | 1.8 | 8.0E+01 | 1.6E+02 | 1.2E-04 | 4.8E-04 | 1.3E+10 | 1.9E+10 |
| J19TE4:5.5-3CN-R250U | 440024 | 0.25 | -80 | 5.5 | 5.0 | 2.3 | 1.8E+03 | 3.6E+03 | 6.0E-06 | 2.4E-05 | 2.1E+10 | 3.0E+10 |
| J19TE4:5.5-3CN-R01M | 440025 | 1.00 | -80 | 5.5 | 5.0 | 2.2 | 1.8E+02 | 3.6E+02 | 6.0E-05 | 2.4E-04 | 2.5E+10 | 3.6E+10 |
| * J19TE4:5.5-3VN-R250U | 440056 | 0.25 | -90 | 5.5 | 5.0 | 2.4 | 3.0E+03 | 6.0E+03 | 4.0E-06 | 1.6E-05 | 2.9E+10 | 4.2E+10 |
| * J19TE4:5.5-3VN-R01M | 440039 | 1.00 | -90 | 5.5 | 5.0 | 2.4 | 3.0E+02 | 6.0E+02 | 4.0E-05 | 1.6E-04 | 3.7E+10 | 5.3E+10 |

All specs are for detector operation at 0V bias and 180° FOV unless otherwise specified. * 45° FOV. Maximum reverse bias voltage for all detectors is 0.5V. Higher responsivity may be achieved at reverse bias.

3CN Package

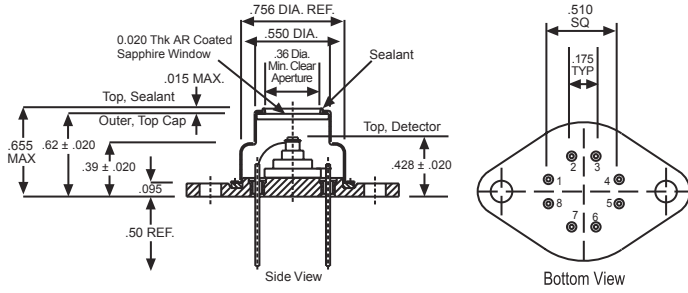

| Pin No. | Designation | Sleeve Color |
|---------|----------------------|--------------|
| 1 | Thermistor | Yellow |
| 2 | Detector Cathode (-) | White |
| 3 | Detector Anode (+) | Green |
| 4 | Cooler (-) | Black |
| 5 | Cooler (+) | Red |
| 6 | N/C | Clear |
| 7 | N/C | Clear |
| 8 | Thermistor | Yellow |

66C/66D Package

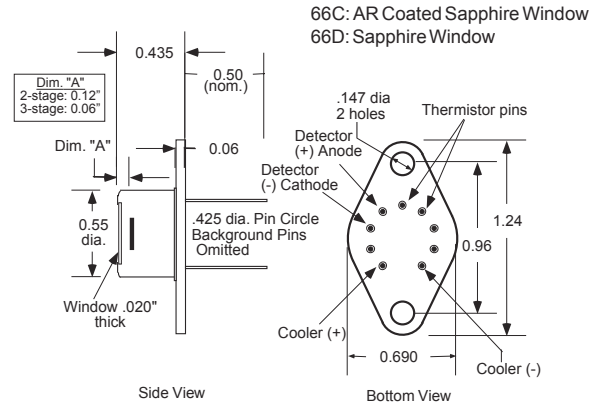

37SP Package

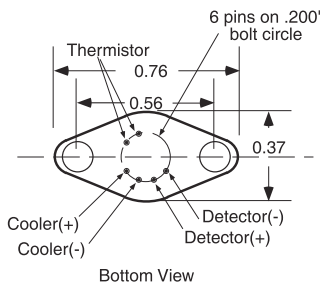
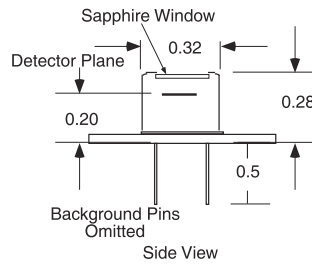

18C Package

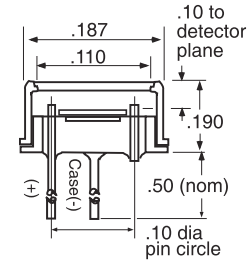

Figure 8
 Detector Temperature vs TE2 Cooler Current

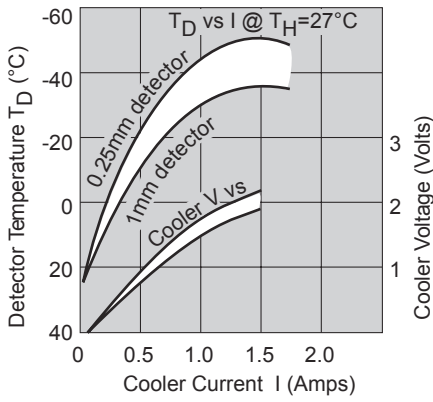

Figure 9
 Detector Temperature vs TE3 Cooler Current

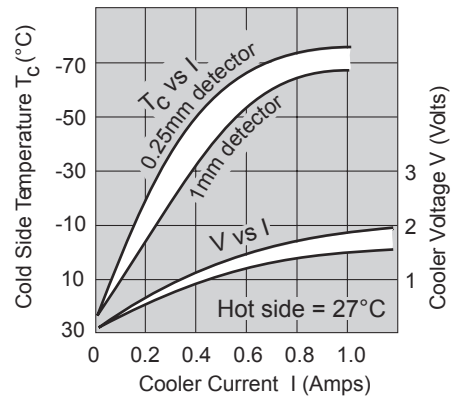
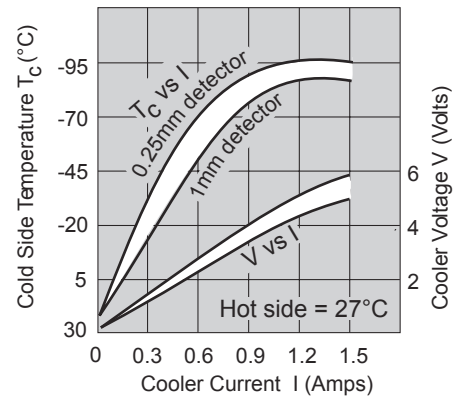

Figure 10
 Detector Temperature vs TE4 Cooler Current



In addition to our Photovoltaic MCT product line, Teledyne Judson Technologies offers a wide range of high performance standard, custom and space qualified detector products and accessories.

- Germanium detectors and arrays
- Indium Arsenide detectors and arrays
- Indium Antimonide detectors and arrays
- Mercury Cadmium Telluride detectors and arrays
- Lead Selenide detectors and arrays
- Lead Sulfide detectors and arrays
- Dewars, backfill and vacuum packages
- Thermoelectric, Joule Thomson and closed cycle linear and rotary coolers
- Preamplifiers
- Temperature controllers and readout electronics

Please contact us for more information on these products at 215-368-6900 or on the web at www.teledynejudson.com.



221 Commerce Drive
Montgomeryville, PA 18936 USA
Tel: 215-368-6900, Fax: 215-362-6107
www.teledynejudson.com

June, 2002