

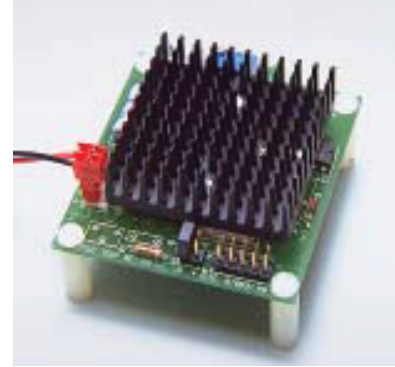

The TC8 is a self contained Thermoelectric Cooler Temperature Controller for single and multistage TEC cooled photodetectors housed in TO-8, TO37, and other TO style packages. Using a single 5 Volt power supply, the TC8 operates in conjunction with a thermistor, located in the detector assembly, to precisely measure and regulate the temperature of the cooled detector. The detector assembly temperature is set with a single resistor that is equal to the thermistor resistance at the desired set temperature. The detector manufacturer generally specifies the optimum detector operating temperature and corresponding thermistor value.



The TC8 contains a connector (P3) for optional monitoring of the TEC current, the current through the temperature set resistor output of the thermistor bridge. Pins on this connector can also be used to set detector temperature with an external resistor or current source if desired. In addition, a solid state switch closure and the illumination of an on board LED is provided when the detector temperature is within $\pm 2^{\circ}\text{C}$ of the programmed temperature.

Interconnect cables are provided with each TC8 controller to interface with the power supply and the detector assembly (TEC-thermistor). A cable is also provided to interface with connector P3.

FEATURES

- PRECISE TEMPERATURE CONTROL
- TEMPERATURE STABILITY TO $\pm 0.02^{\circ}\text{C}$
- TEMPERATURE SET WITH A SINGLE RESISTOR
- SINGLE +5 VOLT POWER SUPPLY OPERATION
- OPERATES WITH MOST TEC COOLED DETECTORS
- MAXIMUM TEC CURRENT ADJUSTABLE TO 2 AMPS
- LED TEMPERATURE STABILIZATION INDICATOR
- TEC CURRENT MONITOR
- THERMISTOR BRIDGE MONITOR
- SMALL SIZE
- DETAILED INSTRUCTION MANUAL PROVIDED

The various electrical inputs and outputs of the TC8 can be monitored and/or controlled through this connector if desired. Making connection to the TC8 through this connector is not necessary to the operation of the controller.

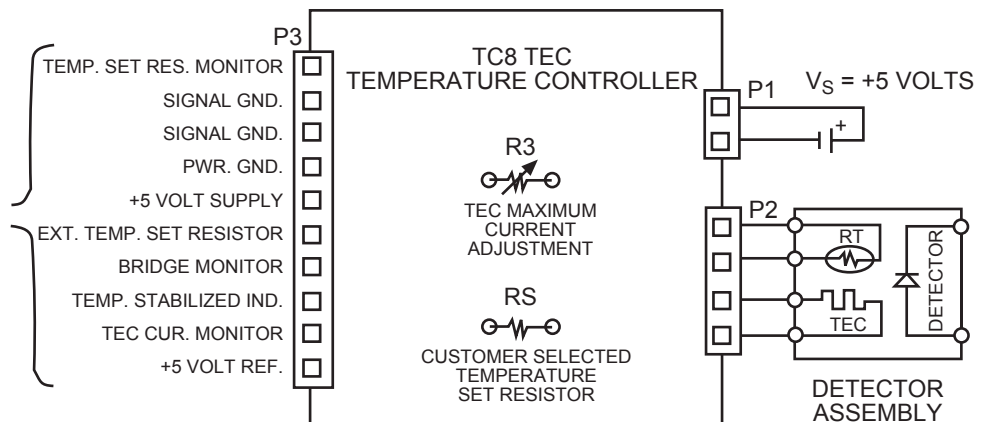

FIGURE 1

The TC8 TEC controller consists of a thermistor bridge amplifier, an integrator/gain stage and a voltage-to-current converter power drive stage. This is illustrated in the simplified schematic diagram for the TC8 in Figure 2. The thermistor bridge precisely measures the temperature of a device attached to a Thermoelectric Cooler (TEC). The bridge is balanced when the thermistor value is equal to the value of the temperature set resistor R_S . When power is first applied to the TEC, the temperature of the device attached to the TEC is higher than the desired set temperature.

The resistance of the thermistor is therefore less than the temperature set resistor. This causes the current sink to turn on to its maximum programmed value. This maximum current is set with resistor R_3 . The TC8 will continue to sink maximum current until the programmed temperature is reached. The current will then decrease to the value required for maintaining equality between the thermistor and the programming resistor (R_S).

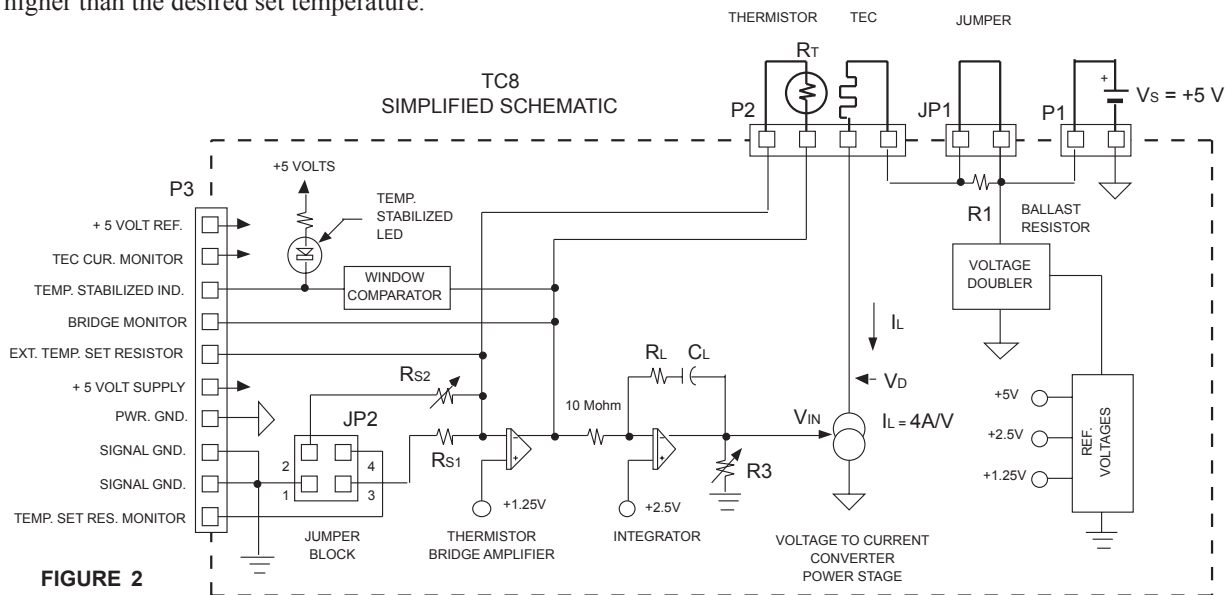

FIGURE 2

SETTING UP THE TC8 TEC CONTROLLER

Do the following before applying power to the TC8 TEC Controller . Refer to the figure on the back page.

1. Rotate R_3 , the TEC current limit control, counter clockwise until it will go no further. This will insure that no current will flow through the TEC when power is applied.
2. Select the desired value of temperature set resistor R_{S1} or R_{S2} and solder it into place. The thermistor in the detector assembly will be forced to this value when the control loop is operating.
3. Select the temperature control resistor location (R_{S1} or R_{S2}) by placing a jumper bar across the appropriate pin on connector JP2. The shorting bar has been placed in the position that selects R_{S1} , at the factory. Shorting bar placement that selects R_{S2} is illustrated in Figure 7.
4. Connect the TEC and thermistor to the TC8 through connector P2. A cable that is unterminated on one end, and with a mating connector for P2 on the other end, is provided for interfacing the TEC and thermistor to the TC8. Make sure the positive terminal of the TEC is connected to the Pin marked (+) on connector P2. Current from this pin into the TEC causes the TEC to cool.

SETTING THE MAXIMUM TEC CURRENT LIMIT

The TEC in the detector module can be damaged if the maximum TEC current limit is exceeded. The maximum current delivered to the TEC by the TC8 can be limited to any level between 0 and 2 Amperes by adjusting potentiometer R_3 . R_3 is turned all the way counter clockwise at the factory so no TEC current will flow when power is applied. Connect a four and one half digit voltmeter between Pin 2 and Pin 8 (ground) of connector P3.

The voltage that will appear between these terminals is proportional to the current flowing through the TEC. The sensitivity is 0.5 Volts per Ampere of TEC current. Connect the +5 Volt power supply to the TC8 and turn the power on. The reading on the volt meter will be zero. Determine the maximum allowable TEC current from the data sheet of the detector manufacturer. Rotate the potentiometer clockwise. At some point the voltage reading on the DVM will increase. Continue to rotate R3 until the desired current level is reached. For example: The voltage between Pin 2 and ground will be adjusted to 0.7 Volts if the maximum allowable TEC current is 1.4 Amperes.

The current through the TEC will decrease from the maximum set value when temperature control occurs. The final TEC current will be the current required to maintain the detector assembly at the set temperature.

THERMISTOR CONTROL BRIDGE MONITOR

This is the output of the thermistor bridge and can be monitored between Pin 4 and and Pin 8 of connector P3. The voltage at this Pin will be approximately +2.500 Volts. The Voltage/temperature sensitivity at Pin 2 is 50 millivolts per degree C when a thermistor with a 4% per degree C temperature coefficient is used. This voltage should not vary more than ± 1 millivolt (± 0.02 °C) once temperature stabilization occurs.

TEMPERATURE STABILIZATION INDICATOR

A circuit internal to the TC8 measures the output of the Thermistor Control Bridge. A solid state switch closure to power ground occurs when the output of this bridge is between 2.4 and 2.6 Volts. This indicates that the temperature of the detector has stabilized to within ± 2 °C of the programmed set temperature. This switch closure occurs between Pin 3 and power ground (Pin 7) of connector P3 and can sink up to 200 milliamperes of current. In addition, a green LED located on the TC8 module illuminates when this switch closes. The illumination of this LED also indicates that the temperature of the detector module has stabilized.

A 2,000 ohm potentiometer (R5) can be inserted into the TC8 printed circuit board to increase the sensitivity of the Temperature Stabilization Indicator. This will narrow the temperature range at which temperature stabilization switch closes and the LED lights up. For instance, the temperature stabilization indicator could be narrowed to ± 0.5 °C if desired.

REMOTE TEMPERATURE CONTROL OF THE TC8

The temperature control resistor for the TC8 can be remotely located from the TC8. This is done by removing the jumper from connector JP2 and placing the desired temperature control resistor between Pin 5 and Pin 8 or Pin 9 of connector P3 (Figure 2A). These pins can be accessed through the ribbon cable that is enclosed with the TC8. The temperature of the detector can also be voltage programmed. All necessary interconnects, including power, are available on connector P3. This is illustrated in Figure 2B.

REMOTE RESISTOR TEMPERATURE PROGRAMMING

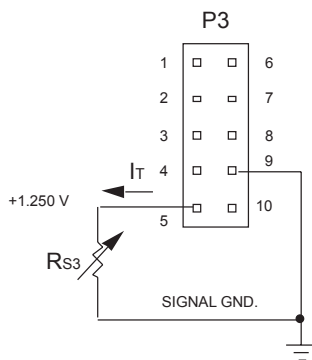

FIGURE 2A

REMOTE VOLTAGE TEMPERATURE PROGRAMMING

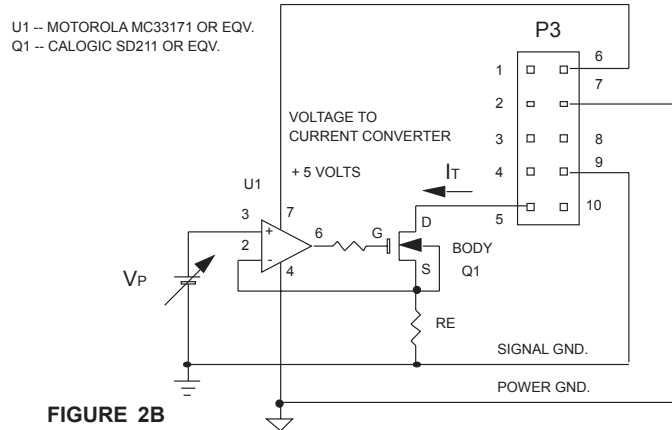

FIGURE 2B

The voltage between Pin 5 and ground (Pin 9) of connector P3 is always +1.250 Volts \pm 2.0%. The thermistor (RT) in the detector assembly will always be forced to be equal to the value of the temperature set resistor RS when temperature stabilization occurs. The following equations therefore apply when setting the detector temperature with an external voltage.

$$(1.1) \quad I_T = \frac{1.250}{R_S} \quad \text{When the temperature is stabilized } R_T = R_S \text{ or: } (1.2) \quad I_T = \frac{1.250}{R_T}$$

The current flowing from Pin 5 is given by equation (1.3) when voltage programming is used as illustrated in

$$(1.3) \quad I_T = \frac{V_P}{R_E} = \frac{1.250}{R_T} \quad \text{Thus: } V_P = 1.250 \frac{R_E}{R_T} = \text{The input voltage required to program the thermistor to a final set value of } R_T.$$

Example:

Let $R_E = 800$ and $R_T = 13.7K$ which is the thermistor resistance at the desired set temperature of $-25^\circ C$. Then:

$$(1.5) \quad V_{IN} = 1.250 \frac{800}{13,700} = 0.073 \text{ Volts} \quad \text{This is the voltage required to program the detector to } -25^\circ C.$$

The input voltage (VP) to the circuit in Figure 2B should always be less than 0.6 volts otherwise improper operation may occur.

POWER CONSIDERATIONS

A one ohm power resistor (R1) that is in series with the TEC and the power driver, is incorporated on the TC8 P.C. board (Figure 3). This resistor should be used if a TEC with a very low resistance is used, otherwise it is possible to operate the power stage of the TC8 at power level in excess of the 6 Watt maximum rating. A jumper across connector JP1 will short R1 out if it is not needed. Note that the current flowing through the TEC, the 1 resistor (if used) and the TC8 power stage is the same and that the power supply voltage (VS) is divided between these three elements. A load line technique can be used to determine the voltage drop across each of these elements. This will show if the power dissipated in the TC8 current source can exceed the six watt limit which in turn will determine if the 1 resistor is needed. This is accomplished by superimposing a load line for the TEC on the Current-Voltage characteristic of the TC8 power stage illustrated in Figure 4.

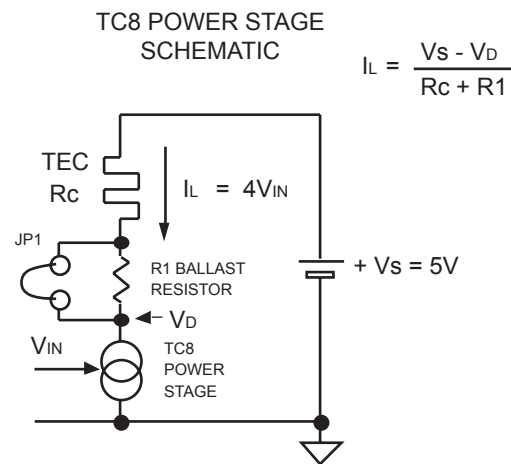

FIGURE 3

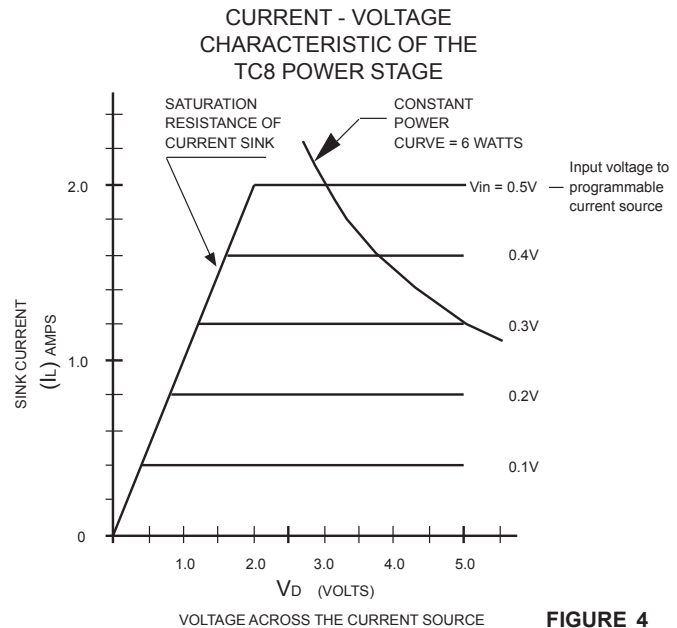

FIGURE 4

From the TEC specifications determine the maximum voltage and current limits and calculate the equivalent resistance. For example: Suppose the TEC is rated at 2 Amperes maximum at a maximum operating voltage of 0.48 Volts. This is equivalent to a resistance of 0.24 . To obtain the load line draw a line, with a slope of 1 divided by the resistance, through 5 Volts on the (X) axis in Figure 5. This line defines the locus of operating point for the circuit in Figure 3 and is illustrated in Figure 5.

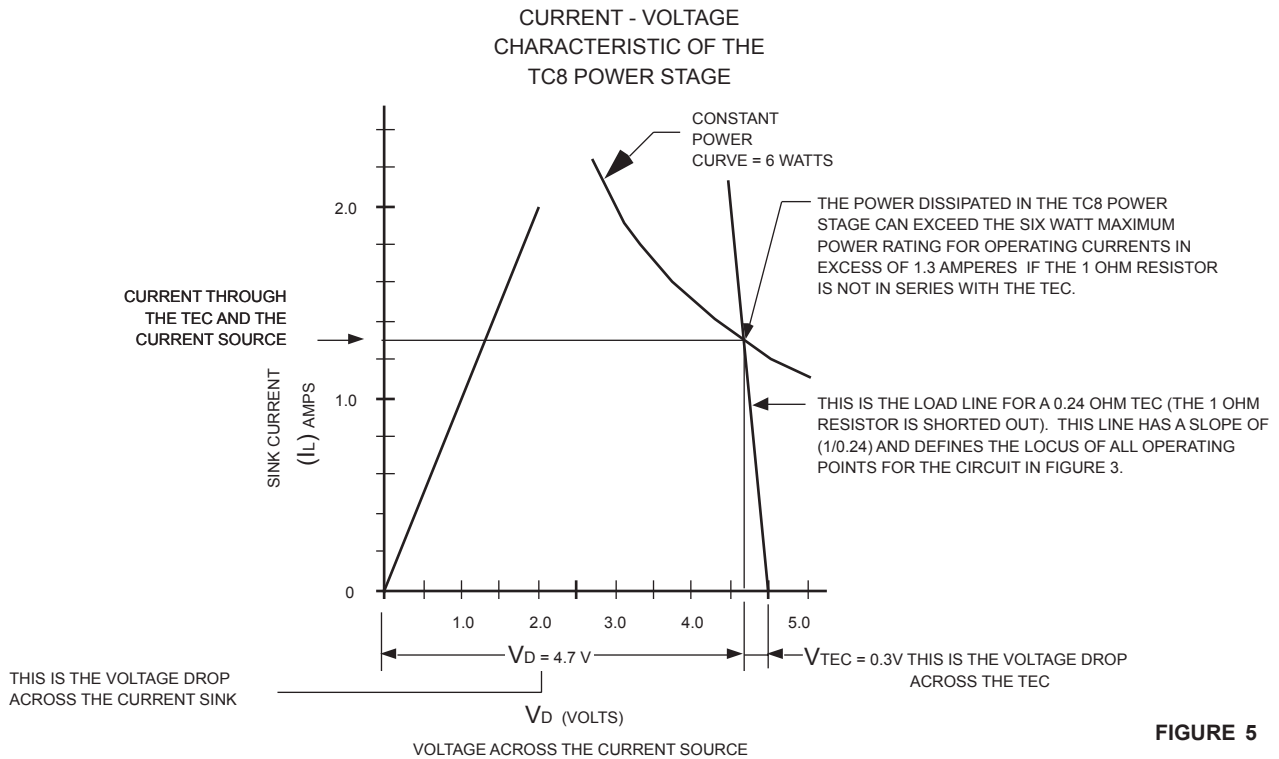

FIGURE 5

It can be seen from Figure 5 that the power dissipation in the TC8 current sink can be exceeded for TEC drive currents in excess of 1.3 Amperes. The problem can be rectified by placing the 1 Ohm resistor in series with the TEC (remove the jumper). Now the resistance in series with the current sink is 1.24 Ohms and the load line passes through 5 Volts on the (X) axis and has a slope of 1 divided by 1.24. This line defines the new locus of operating point for the circuit in Figure 3 and is illustrated in Figure 6.

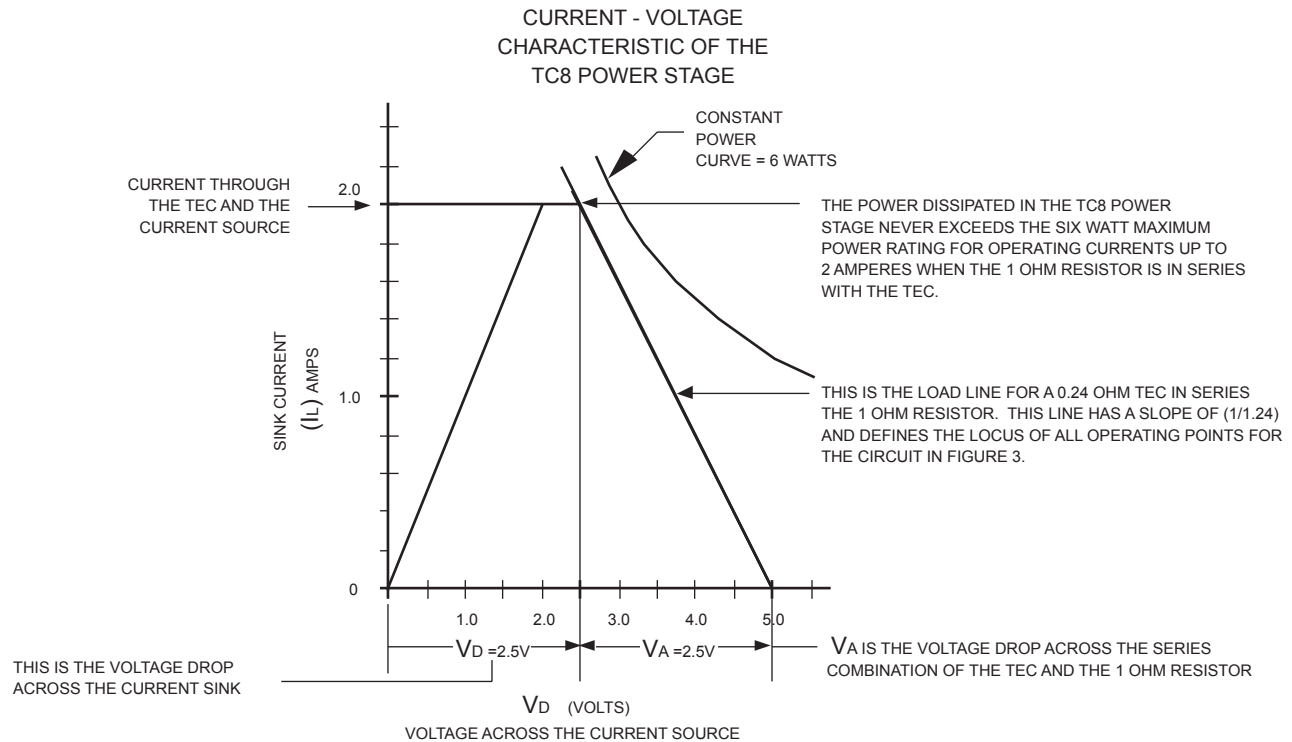

FIGURE 6



The figure on this page illustrates the location and function of the connectors and components on the TC8. The temperature set resistor (RS1 or RS2) are customer installed. Selection of the fixed resistor RS1 or variable resistor RS2 is made by placing a jumper in the specified location on connector JP2. A 1 ohm ballast resistor is provided on the TC8. This resistor is in series with the TEC and is used to properly match the TC8 to very low resistance TECs. This resistor can be shorted out if not needed by placing a jumper across JP1. The various control voltages of the TC8 can be monitored through connector P3. The pin location of these signals is shown below.

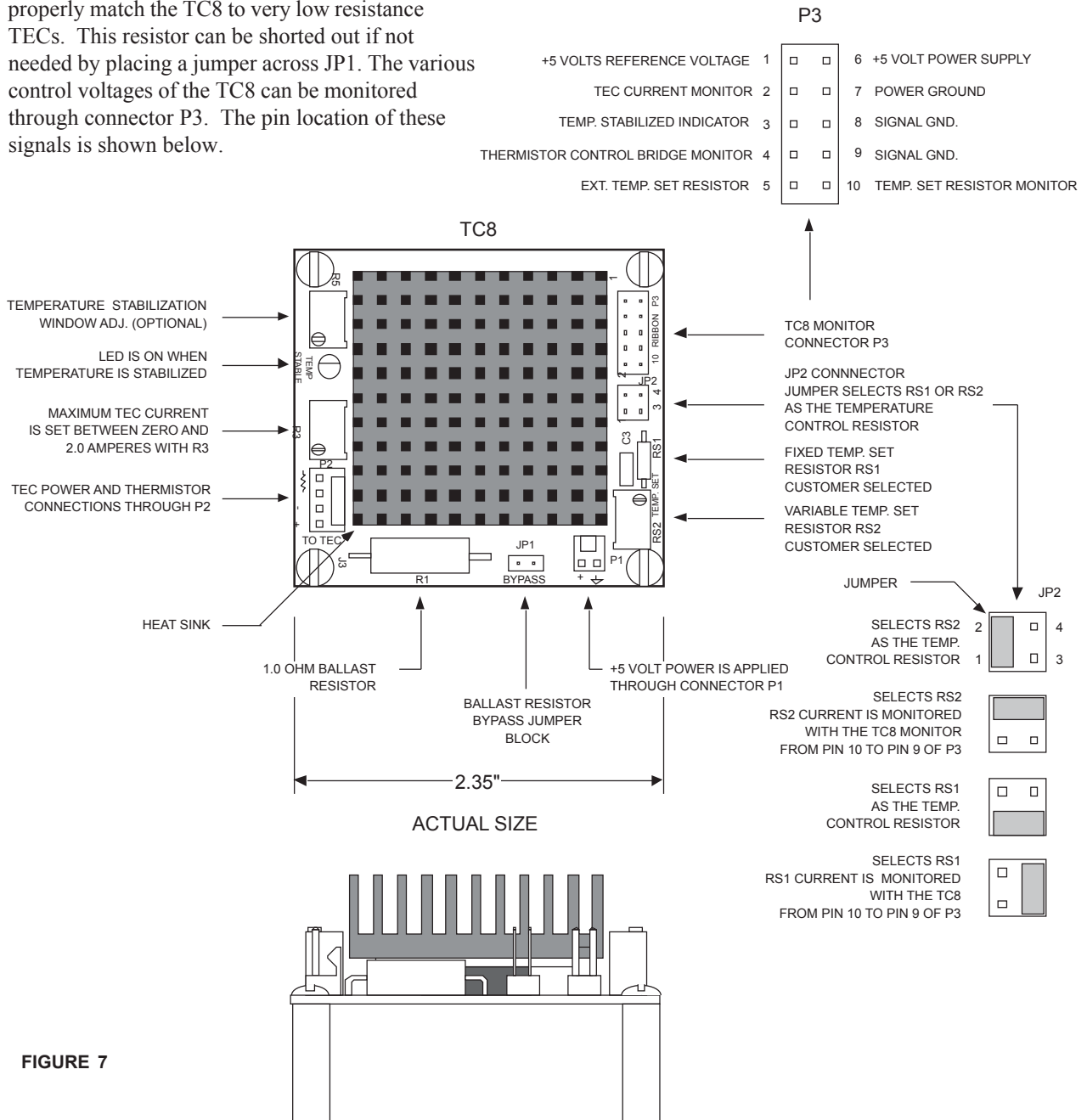

FIGURE 7

Information in this document is believed to be reliable. However, no responsibility is assumed for possible inaccuracies or omission. Specifications are subject to change without notice.